

## 65Tii40MTL Drainage System

### Product Description

The 65Tii40 is a premium tile insert drain suitable for tiles up to 25mm thick.

The 65Tii40MTL is made to specific lengths with a customized outlet position along the drain.

The complete drainage unit is full 316 marine grade stainless steel.

The maximum length of the tile insert will be 1200mm in one piece, channels longer than 1200mm will have inserts in multiple equal sections



### Applications

- Balcony
- Bathroom
- Courtyard
- Doortrack
- Patio
- Paved Area
- Pool Area
- Shower
- Special needs
- Wet Area Drainage

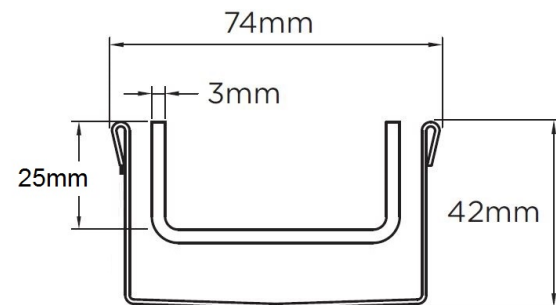

### Specifications

	Width	Depth	Length	Outlet size
<b>Completed Unit</b>	74mm	42mm	As required	DN40 DN50 DN65

