

# VC100-45 Vinyl Clamp Drainage System

## Product Description

The VC100-45 vinyl clamp allows the use of a linear drain in a vinyl floor environment. It is particularly well adapted for drainage needs in hospitals, commercial kitchens or schools.

It is manufactured from 316 marine grade steel and features a wedge wire architectural style grate and channel in which a screw mechanically clamps the vinyl beneath.

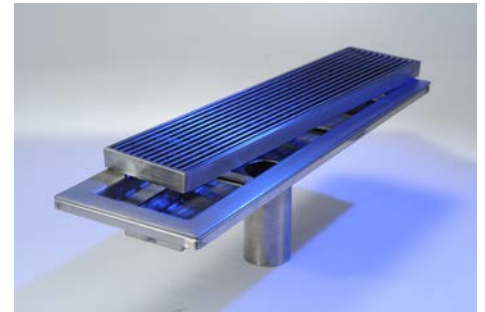

## Applications

- Bathroom
- Shower
- Special needs
- Threshold
- Wet Area Drainage

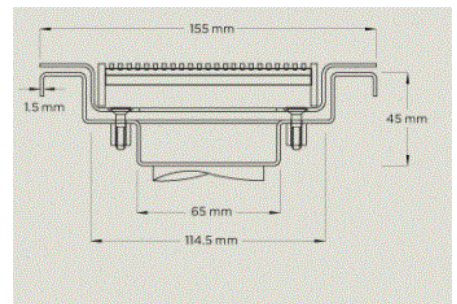

## Specifications

	Width	Depth	Length	Outlet size
<b>Assembled unit</b>	155mm	45mm	As per specifications	DN40 DN50
<b>Grate only</b>	100mm	20mm	As per specifications	

