

**65AS components**

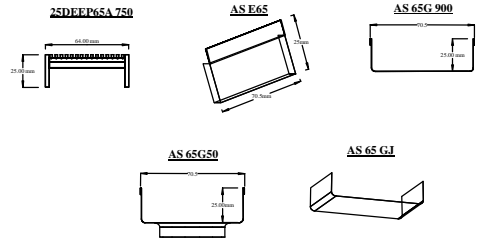

**Specific tools required**

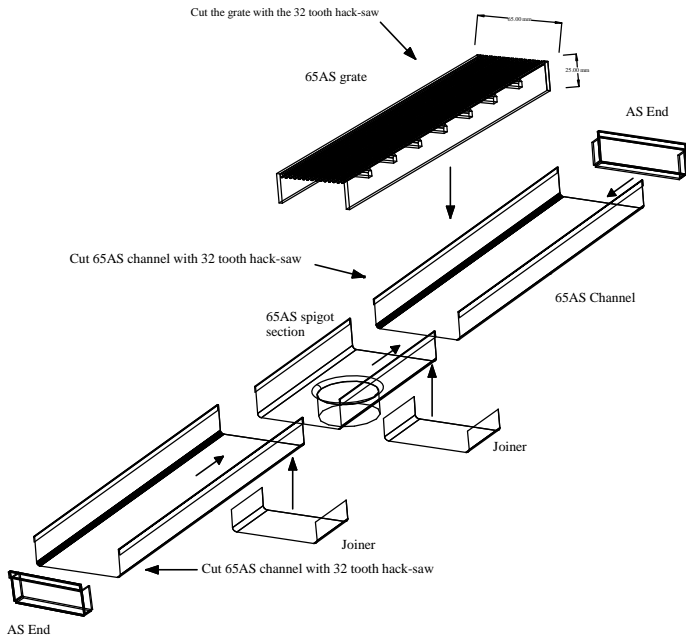
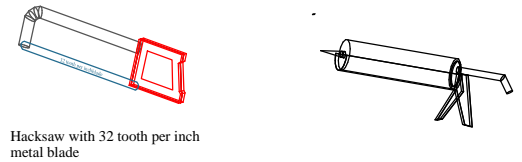

Use high quality silicone for fixing on ends, and joining sections. Ensure no gaps

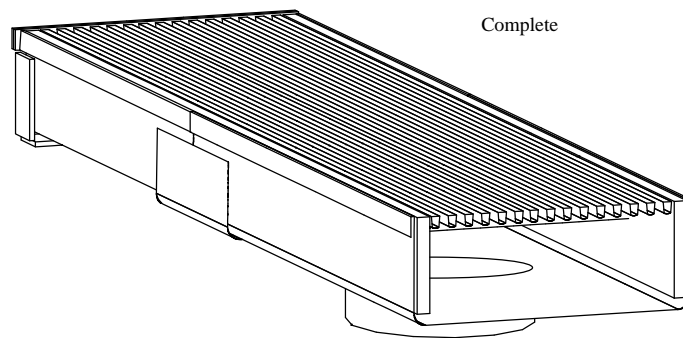

Complete

STEP 1, lay out the components in the intended area of installation.

STEP 2, Position the AS65G50 spigot section above the pipe/outlet in floor. Ensure spigot fits inside the pipe. If spigot does not fit inside pipe, make an extension using PVC or stainless steel pipe.

STEP 3, Using a 32 tooth hack-saw, cut the AS65G channel to the size required, less the length of the spigot section.

STEP 4, Check all measures & alignment.

STEP 5, Using a high quality silicone, join the channel and spigot sections with the joiners. Ensure no gaps, & no lips inside the channel. Repeat to fix on the end caps.

STEP 6, Using a 32 tooth hack-saw blade, cut the grate to size. Ensure the grate is not too tight in the channel to allow for easy removal.