

# 100MNDTDiBF Threshold Drainage

## Product Description

The 100MNDTDiBF features a concealed channel section connecting top hung and bi-fold door tracks and thresholds. It is completed with a MND grate that was created in collaboration with Marc Newson featuring a tessellated hexagonal design..

Allows Top hung and bi-fold doors to be drained while having internal and external floor surfaces with no step down.

Manufactured from 316 marine grade stainless steel to specific lengths.

## Applications

- Balcony
- Courtyard / Patio
- Special needs
- Suspended slab
- Wet Area Drainage

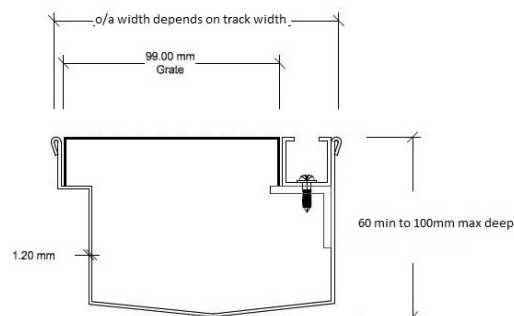

## Specifications

	Width	Depth	Length	Outlet size
Unit	o/a depends on track width	As required	As required	As required

